

## UNIT II: Boolean Algebra and Karnaugh Maps (TUTORIAL SHEET)

Q1. Simplify the following Boolean expressions to minimum number of literals:

(a)\*  $xy + xy'$

(b)\*  $(x + y)(x + y')$

(c)\*  $xyz + x'y + xyz'$

(d)\*  $(A + B)'(A' + B)'$

(e)  $(a + b + c')(a'b' + c)$

(f)  $a'bc + abc' + abc + a'bc'$

Q2. Draw the logic diagrams to implement the original and minimized expression for Q1.

Q3. Find the dual and the complement of following expressions:

(a)\*  $xy' + x'y$

(b)  $(a + c)(a + b')(a' + b + c')$

(c)  $z + z'(v'w + xy)$

Q4. List the truth table of following functions:

(a)\*  $F = xy + xy' + y'z$

(b)  $F = bc + a'c'$

Q5. Implement the Boolean function:

$$F = xy + x'y' + y'z$$

Using:

OR-AND implementation

AND-OR implementation

NAND implementation

NOR implementation

Q6. Obtain truth table for following values, and express each function in SOP and POS form:

(a)\*  $(b + cd)(c + bd)$

(b)  $(cd + b'c + bd')(b + d)$

(c)  $(c' + d)(b + c')$

(d)  $bd' + acd' + ab'c + a'c'$

Q7. Show that the dual of exclusive-OR is equal to its complement.

Q8. Show that a positive logic NAND gate is a Negative logic NOR gate and vice-versa.

Q9: Obtain the Boolean expression and simplify the equation for the following Logic gates:

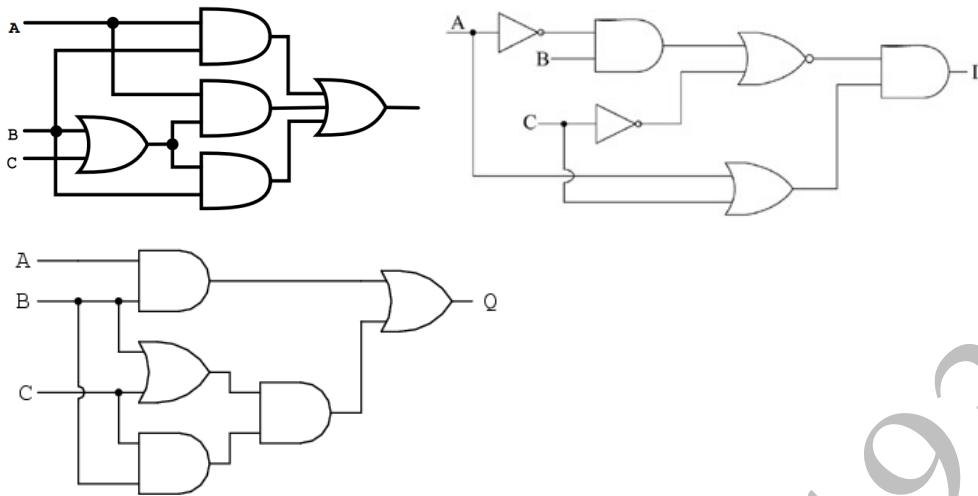

Q10. Simplify the following Boolean functions, using three variable K-map:

(a)  $F(x, y, z) = \Sigma(0, 2, 4, 5)$

(b)  $F(x, y, z) = \Sigma(0, 2, 4, 5, 6)$

(c)  $F(x, y, z) = \Sigma(0, 1, 2, 3, 5)$

(d)  $F(x, y, z) = \Sigma(1, 2, 3, 7)$

Q11. Simplify the following Boolean functions, using four variable K-map:

(a)\*  $F(w, x, y, z) = \Sigma(1, 4, 5, 6, 12, 14, 15)$

(b)  $F(A, B, C, D) = \Sigma(2, 3, 6, 7, 12, 13, 14)$

(c)  $F(w, x, y, z) = \Sigma(1, 3, 4, 5, 6, 7, 9, 11, 13, 15)$

(d)\*  $F(A, B, C, D) = \Sigma(0, 2, 4, 5, 6, 7, 8, 10, 13, 15)$

Q12. Simplify the following Boolean functions, using four variable K-map:

(a)\*  $A'B'C'D' + AC'D' + B'CD' + A'BCD + BC'D$

(b)\*  $x'z + w'xy' + w(x'y + xy')$

(c)  $A'B'C'D + AB'D + A'BC' + ABCD + AB'C$

(d)  $A'B'C'D' + BC'D + A'C'D + A'BCD + ACD'$

Q13. Find prime implicants of following functions, using K-map:

(a)\*  $F(w, x, y, z) = \Sigma(0, 2, 4, 5, 6, 7, 8, 10, 13, 15)$

(b)\*  $F(A, B, C, D) = \Sigma(0, 2, 3, 5, 7, 8, 10, 11, 14, 15)$

(c)  $F(A, B, C, D) = \Sigma(2, 3, 4, 5, 6, 7, 9, 11, 12, 13)$

Q14. Find essential prime implicants of following functions, using K-map:

(a)  $F(w, x, y, z) = \Sigma(0, 2, 5, 7, 8, 10, 12, 13, 14, 15)$

(b)  $F(A, B, C, D) = \Sigma(0, 2, 3, 5, 7, 8, 10, 11, 14, 15)$

(c)\*  $F(A, B, C, D) = \Sigma(1, 3, 4, 5, 10, 11, 12, 13, 14, 15)$

Q15. Find simplified expression using don't care conditions, using K-map:

(a)  $F(x, y, z) = \Sigma(0, 1, 4, 5, 6)$

$d(x, y, z) = \Sigma(2, 3, 7)$

(b)\*  $F(A, B, C, D) = \Sigma(0, 6, 8, 13, 14)$

$d(A, B, C, D) = \Sigma(2, 4, 10)$

Irfan Pindoo 19390

### BRAIN TEASERS:

Q16. A safe has 5 locks: v,w,x,y, all of which must be unlocked for the safe to open.?

The keys to the locks are distributed among five executives in the following manner:

Mr. A has keys for locks v & x

Mr. B has keys for locks v & y

Mr. C has keys for locks w & y

Mr. D has keys for locks x & z

Mr. E has keys for locks v & z

i. Determine the minimal no. of executives required to open the safe.

ii. Find all the combinations of executives that can open the safe, write an expression  $f(A,B,C,D,E)$  which specifies when the safe can be opened as a function of which executives are present.

iii. Who is the 'essential executive' without whom the safe cannot be opened.

Q17. You are presented with a set of requirements under which an insurance policy will be issued.

The applicant must be:

- A married female 25 years old or over, or
- A female under 25, or
- A married male under 25 who has not been involved in a car accident, or
- A married male who has involved in a car accident, or
- A married male 25 years or over who has not been involved in a car accident.

The variables w, x, y, and z assume the truth value 1 in the following cases:

- w = 1 if applicant has been involved in a car accident
- x = 1 if applicant is married
- y = 1 if applicant is a male
- z = 1 if applicant is under 25

You are asked to find an algebraic expression which assumes the value 1 whenever the policy should be issued. Simplify algebraically the above expression and suggest a simpler set of requirements. Finally design a logic circuit for the derived expression.

Q18. Five soldiers, A, B, C, D, and E, volunteer to perform an important military task if the following conditions are satisfied.

- Either A or B or both must go.
- Either C or E, but not both, must go.
- Either both A and C go or neither goes.
- If D goes then E must also go.
- If B goes then A and D must also go.

Define variables A, B, C, D, E such that an unprimed variable will mean that the corresponding soldier has been selected to go. Determine the expression that specifies the combinations of volunteers that can get the assignment.

## UNIT II: Boolean Algebra and Karnaugh Maps (GATE PROBLEMS)

Q1. A function  $F(A, B, C)$  defined by three Boolean variables  $A, B$  and  $C$  when expressed as sum of products is given by

$$F = \overline{A} \cdot \overline{B} \cdot \overline{C} + \overline{A} \cdot B \cdot \overline{C} + A \cdot \overline{B} \cdot \overline{C}$$

The product of sums (POS) form of the function  $F$  is \_\_\_\_\_

Q2. For an  $n$  - variable Boolean function maximum number of prime implicants is

- (a)  $2n - 1$    (b)  $n/2$    (c)  $2^n$    (d)  $2^{(n-1)}$

Q3. The Boolean expression  $(X+Y)(X+\overline{Y}) + ((\overline{X\overline{Y}}) + \overline{X})$  simplifies to

- (a)  $X$    (b)  $Y$    (c)  $XY$    (d)  $X+Y$

Q4. The Boolean function  $A + BC$  is a reduced form of

- a.  $AB + BC$   
b.  $(A + B)(A + C)$   
c.  $A'B + AB'C$   
d.  $(A + C)B$

Q5. For the identity,  $AB + A'C + BC = AB + A'C$ , the dual form is

- (a)  $(A+B)(\overline{A}+C)(B+C) = (A+B)(\overline{A}+C)$   
(b)  $(\overline{A}+\overline{B})(A+\overline{C})(\overline{B}+\overline{C}) = (\overline{A}+\overline{B})(A+\overline{C})$   
(c)  $(A+B)(\overline{A}+C)(B+C) = (\overline{A}+\overline{B})(A+\overline{C})$   
(d)  $\overline{A}\overline{B} + A\overline{C} + \overline{B}\overline{C} = \overline{A}\overline{B} + A\overline{C}$

Q6. The logical expression  $Y = A + A'B$  is equivalent to

- a.  $AB$   
b.  $A'B$   
c.  $A' + B$   
d.  $A + B$

Q7. The minimized form of the logical expression

$$(\overline{A}\overline{B}\overline{C} + \overline{A}B\overline{C} + \overline{A}BC + ABC)$$

- (a)  $\overline{A}\overline{C} + B\overline{C} + \overline{A}B$    (b)  $A\overline{C} + \overline{B}C + \overline{A}B$   
(c)  $\overline{A}C + \overline{B}C + \overline{A}B$    (d)  $A\overline{C} + \overline{B}C + \overline{A}B$

- Q8. The number of distinct Boolean expressions of 4 variables is
- a. 16
  - b. 256
  - c. 1024
  - d. 65536

- Q9. The Boolean expression for the truth table shown is

A	B	C	f
0	0	0	0
0	0	1	0
0	1	0	0
0	1	1	1
1	0	0	0
1	0	1	0
1	1	0	1
1	1	1	0

- (a)  $B(A+C)(\bar{A}+\bar{C})$
- (b)  $B(A+\bar{C})(\bar{A}+C)$
- (c)  $\bar{B}(A+\bar{C})(\bar{A}+C)$
- (d)  $\bar{B}(A+C)(\bar{A}+\bar{C})$

GATEpaper.in

- Q10. The Boolean function  $Y = AB + CD$  is to be realized using only 2 input NAND gates. The minimum number of gates required is
- a. 2
  - b. 3
  - c. 4
  - d. 5

- Q11. The Boolean expression simplifies to

$$(X+Y)(X+\bar{Y}) + \overline{(X\bar{Y})} + \bar{X}$$

- (A) X
- (B) Y
- (C) XY
- (D) X+Y

- Q12. For the given Boolean function, which one of the following is the complete set of essential prime implicants?

$$F(w, x, y, z) = wy + xy + \bar{w}xyz + \bar{w}\bar{x}y + xz + \bar{x}\bar{y}\bar{z}.$$

- (A)  $w, y, xz, \bar{x}\bar{z}$
- (B)  $w, y, xz$
- (C)  $y, \bar{x}\bar{y}\bar{z}$
- (D)  $y, xz, \bar{x}\bar{z}$

Q13. What is the minimal form of the Karnaugh map shown below? Assume that X denotes a don't care term.

cd \ ab	00	01	11	10
00	1	x	x	1
01	x			1
11				
10	1			x

- (A)  $b'd'$
- (B)  $b'd' + b'c'$
- (C)  $b'd' + a'b'c'd'$
- (D)  $b'd' + b'c' + c'd'$

Q14. For the circuit shown below, the output F is given by \_\_\_\_\_

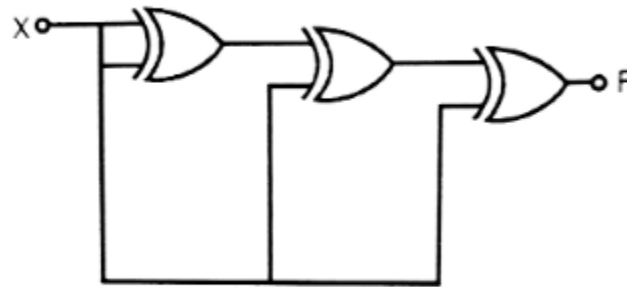

- (a)  $F = 1$
- (b)  $F = 0$
- (c)  $F = X$
- (d)  $F = \bar{X}$

Q15. Minimum number of 2 input NAND gates required to implement the function given below is

Ans=B

$$F = (\bar{X} + \bar{Y})(Z + W)$$

- (a) 3
- (b) 4
- (c) 5
- (d) 6

Q16. Boolean expression for the output of XNOR logic gate with inputs A and B is

- a.  $AB' + A'B$
- b.  $(AB)' + AB$
- c.  $(A' + B)(A + B')$
- d.  $(A' + B')(A + B)$

Q17. The output of the circuit shown in figure is equal to

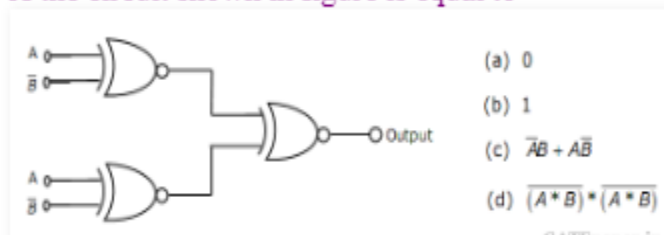

- (a) 0
- (b) 1
- (c)  $\bar{A}B + A\bar{B}$
- (d)  $(A * B) * (A * B)$

Q18. The minimum number of NAND gates required to implement the Boolean function  $A + AB' + AB'C$  is equal to

- a. Zero
- b. 1
- c. 4
- d. 7

Q19. The minimum number of 2 input NAND gates required to implement the Boolean function  $Z = AB'C$ , assuming that A, B and C are available, is

- a. Two
- b. Three
- c. Five
- d. Six

Q20. For the logic circuit shown, the simplified Boolean expression for the output Y is

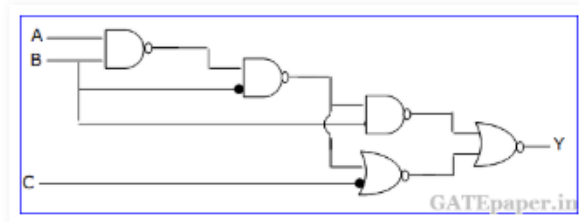

- a.  $A + B + C$
- b. A
- c. B
- d. C

Q21. In the figure, the LED

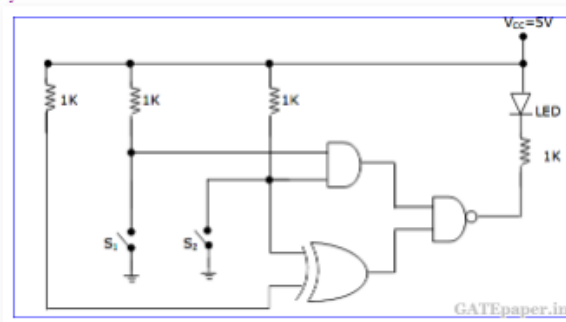

- a. Emits light when both  $S_1$  and  $S_2$  are closed.
- b. Emits light when both  $S_1$  and  $S_2$  are open.
- c. Emits light when only of  $S_1$  or  $S_2$  is closed.
- d. Does not emit light, irrespective of the switch positions.